



 **resto italia**<sup>®</sup>  
CATERING EQUIPMENT MANUFACTURERS

Resto Italia's products support professionals with their italian quality.

**FORNI A GAS LINEA RG**  
GAS OVENS RG LINE

[www.restoitalia.com](http://www.restoitalia.com)

## FORNI A GAS LINEA RG

GAS OVENS RG LINE

I forni a gas serie RG ideale per pizzerie e rosticcerie.

Sono costruiti in acciaio inox e in lamiera preverniciata. Piano di cottura in pietra refrattaria. Isolamento in lana di roccia evaporata. Scarico vapori a centro camera. Illuminazione interna. Alimentazione a gas con valvole di sicurezza con ugelli installati per GPL ed in dotazioni quelli per il gas metano. Bruciatori posti sotto la pietra. **Progettati per cucinare ottimamente le pizze più fantasiose e raffinati piatti di gastronomia.**

The gas ovens RG line is made for pizza and roasted foods.

It is made of stainless steel and coated metal sheet. Firestone cook top. Evaporated mineral wool isolation. Vapors exhaust at the center of backing chamber. Interior lighting. Gas supply with safety valves with installed nozzles for LPG and equipped with those for the methane gas. Burners placed under the stone. **Designed to cook the perfect pizza and sophisticated dishes.**



Nei forni della Linea RG, tramite le varie manopole poste sul quadro di comando, è possibile regolare la distribuzione del calore in modo differente all'interno della camera di cottura. In base alle necessità, si può scegliere una temperatura diversa tra cielo e platea.

In the RG Line ovens, using the various knobs on the control panel, you can adjust the heat distribution in a different way inside the cooking chamber. As needed, you can choose a different temperature between top and bottom.



La qualità Italiana al servizio dei professionisti del mestiere.  
Italian quality at the service of the craft professionals.

	OVEN RG 4	OVEN RG 6	OVEN RG 9
DIMENSIONI INTERNE cm INSIDE DIMENSIONS cm	62 62 15,5	62 92 15,5	92 92 15,5
DIMENSIONI ESTERNE cm OUTSIDE DIMENSIONS cm	100 92/108 47,5	100 122/138 47,5	131 122/138 47,5
DIMENSIONI IMBALLO cm PACKAGE DIMENSIONS cm	100 100 64	100 135 64	135 135 64
CAMERA COTTURA n° BAKING CHAMBER n°	1	1	1
BRUCIATORI n° BURNERS n°	4	4	6
POTENZA KW POWER KW	13.2	21.0	27.0
TEMPERATURA °C TEMPERATURE °C	450°	450°	450°
PESO Kg WEIGHT Kg	92	120	145
TOTALE PIZZE Ø 30 cm TOTAL PIZZA Ø 30 cm			
N° TEGLIE 60X40 cm N° OF PANS 60X40 cm	1	2	2
CODICE CODE	7020221RG4	7020221RG6	7020221RG9
Specificare tipo di gas: metano o GPL (butano o propano) - Specify methane gas or LPG (butane o propane)			
I forni sono sovrapponibili uno sopra l'altro per un massimo di due - The ovens are stackable one above the other for a maximum of two			

CAMINO ANTIVENTO - B11  
CHIMNEY - B11

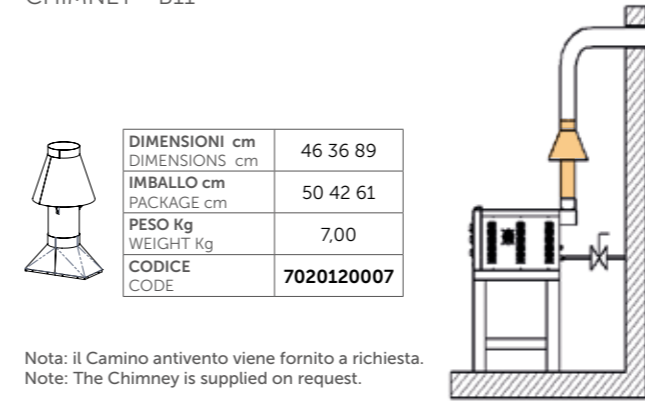

Nota: il Camino antivento viene fornito a richiesta.  
Note: The Chimney is supplied on request.

RACCORDO FUMI PER SOVRAPPORRE FORNO  
EXHAUSTER CONNECTION FOR STACKABLE OVENS

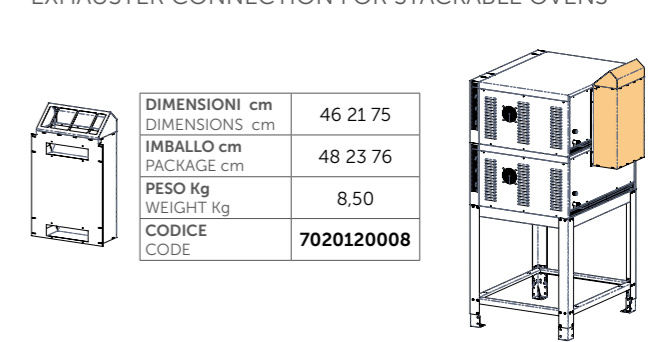

Nota: Il raccordo fumi verrà fornito a richiesta.  
Note: The exhauster connection for stackable ovens is supplied on request.



SUPPORTO REGOLABILE  
ADJUSTABLE SUPPORT

Schema di installazione forni linea RG  
Oven technical setting diagram

Tipo A1 - Type A1  
Tipo B21 - Type B21  
Tipo B11 - Type B11

Cappa - Hood

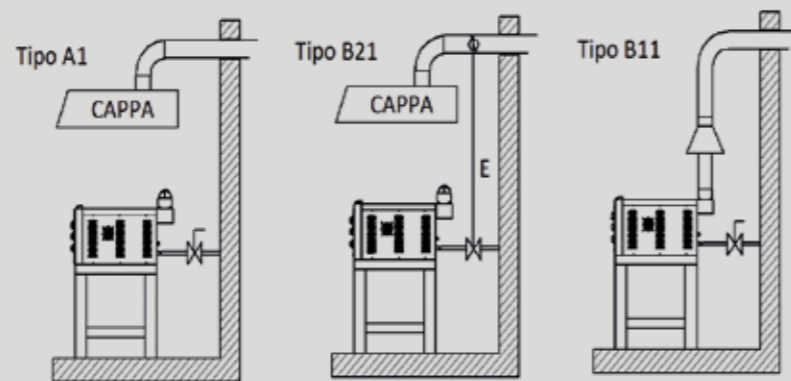

	DIMENSIONI cm DIMENSIONS cm	IMBALLO cm PACKAGE cm	PESO Kg WEIGHT Kg	OPTIONAL OPTIONAL	CODICE CODE
	SUPPORTO RG 4 RG 4 SUPPORT	101,6 88,1 96	105 30 20	25,50	/ 7020100013
	SUPPORTO RG 6 RG 6 SUPPORT	101,6 124,1 96	130 30 20	27,00	/ 7020100014
	SUPPORTO RG 9 RG 9 SUPPORT	132,6 124,1 96	140 30 20	29,00	/ 7020100015
	KIT PORTA TEGLIE RG 4 TRAYHOLDER KIT RG 4	/	100 30 20	5,00	/ 7020110006
	KIT PORTA TEGLIE RG6/9 TRAYHOLDER KIT RG 6/9	/	130 30 20	6,50	/ 7020110004
	COPPIA ANGOLARI RG 4 CORNERS COUPLE RG 4	/	90 10 10	1,10	/ 7020110011
	COPPIA ANGOLARI RG 6 - RG 9 CORNERS COUPLE RG 6 - RG 9	/	130 10 10	1,50	/ 7020110012
	KIT RUOTE CASTORS KIT	/	30 20 20	5,00	/ 7020110001

Scopri tutta la gamma  
dei prodotti Resto Italia

Discover the Resto Italia's  
full range of products



 **resto italia**<sup>®</sup>  
CATERING EQUIPMENT MANUFACTURERS

**Tecno A srl**

Via del Lavoro, 4  
Loc. Canavaccio 61029  
Urbino PU Italy  
T. +39 0722 354048  
F. +39 0722 354049

[info@restoitalia.com](mailto:info@restoitalia.com)  
[www.restoitalia.com](http://www.restoitalia.com)