



# XENA-03HS-MADN.0

English	Technical data
01 Power	3 kW   10236 BTU/h
02 Frequency	50 / 60 Hz
03 Electric nominal heat input	2.9 kW   9895 BTU/h
06 Power supply cable type	H07RN-F
07 Voltage Power cable section Circuit breaker	220-240V ~1PH+N+PE 3G x 1,5 mm <sup>2</sup> 16 A I <sub>n</sub> 14 A In 14 A
08 Cable   Plug   El. Conn. mode	✓   Schuko   -
09 RCD / GFCI	AC
12 Water max. consumption (steam)	NaN l/h @ 200 kPa   NaN gal/h @ 29 psi
14 Max. food load	18 kg   40 lbs
15 Max. temperature	260 °C   500 °F
16 IP protection class	X3

Italiano
01 Potenza
02 Frequenza
03 Potenza termica nominale elettrica
06 Tipo cavo alimentazione
07 Tensione Sezione cavi alimentazione Magnetotermico
08 Cavo   Spina   Modalità connessione elettrica
09 RCD / GFCI
12 Consumo max acqua (vapore)
14 Max. peso pieno carico
15 Temperatura max.
16 Grado protezione IP

Espanol
01 Potencia
02 Frecuencia
03 Potencia térmica nominal eléctrica
06 Tipo de cable de alimentación
07 Voltaje Sección del cable de alimentación Disyuntor
08 Cable   Enchufe   Modo de conexión eléctrica
09 RCD / GFCI
12 Consumo máximo de agua (vapor)
14 Carga máxima de alimentos
15 Temperatura máxima
16 Grado de protección IP

Français
01 Puissance électrique
02 Fréquence
03 Puissance calorifique nominale électrique
06 Type de câble d'alimentation
07 Tension Section câbles d'alimentation Disjoncteur
08 Câble   Prise   Branchement électrique
09 RCD / GFCI
12 Consommation max. d'eau (vapeur)
14 Charge max. des aliments
15 Température max.
16 Niveau de protection IP

Deutsch
01 Elektrische Leistung
02 Frequenz
03 Elektrische Nennwärmeleistung
06 Stromkabel Typ
07 Spannung Stromkabel Teil Sicherung
08 Leitung   Stecker   Elektrischer Verbindungsmodus
09 RCD / GFCI
12 Maximaler Wasserverbrauch bei Dampfbetrieb
14 Maximale Beladungskapazität
15 Maximale Temperatur
16 IP-Schutzart

Terms and conditions of installations - Observe all local specific standard and regulations for installation and operations.



Русский
01 Мощность
02 Частота
03 Номинальная электрическая потребляемая мощность
06 Тип силового кабеля
07 Напряжение Сечение силового кабеля Токовый автомат
08 Кабель   Вилка   вид электрического соединения
09 RCD / GFCI
12 Максимальное потребление воды (пар)
14 Максимальная нагрузка
15 Максимальная температура
16 Класс защиты IP

中文
01 功率
02 频率
03 电额定热输入
06 电源电缆类型
07 电压 电源电缆截面 断路器
08 电缆和插头   电气连接方式
09 RCD / GFCI
12 最大水消耗 (蒸汽)
14 最大食物负荷
15 最高温度
16 IP保护等级

Português
01 Potência
02 Frequência
03 Potência térmica nominal elétrica
06 Tipo de cabo de alimentação
07 Tensão Seção de cabos de alimentação Disjuntor
08 Cabo   Plugue   Modo de Conexão Elétrica
09 RCD / GFCI
12 Max. consumo de água (vapor)
14 Max. capacidade de alimento
15 Max. temperatura
16 Grau de proteção IP

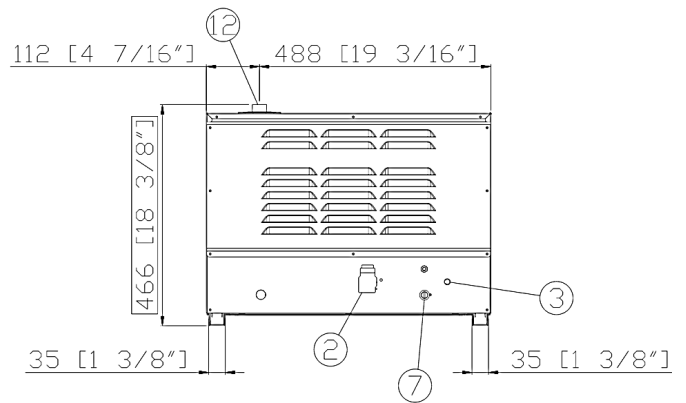
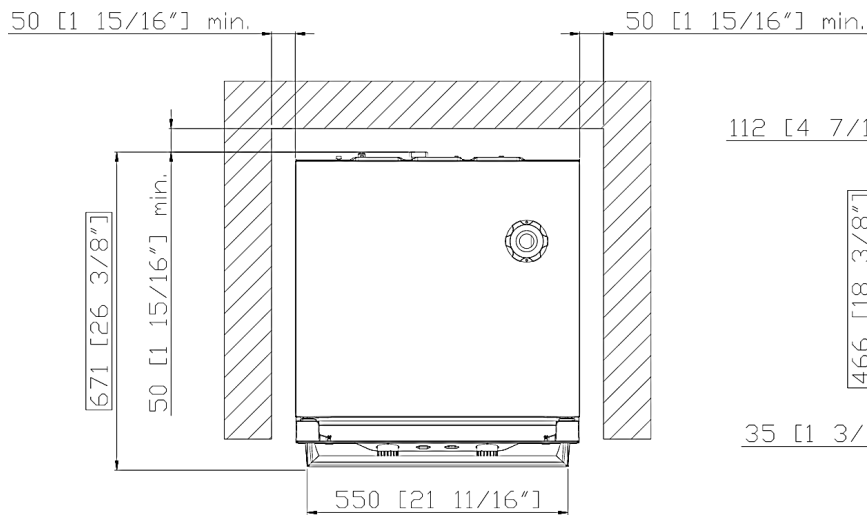
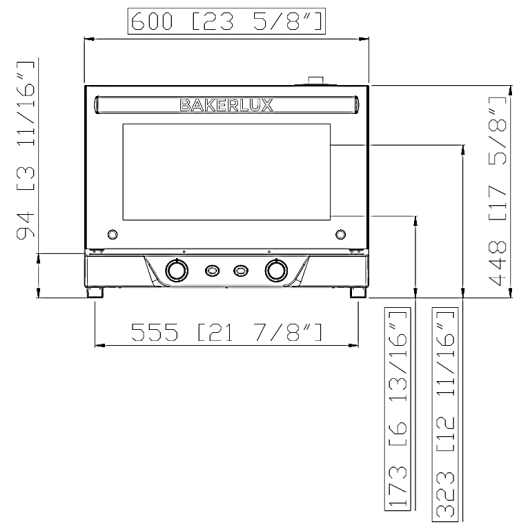
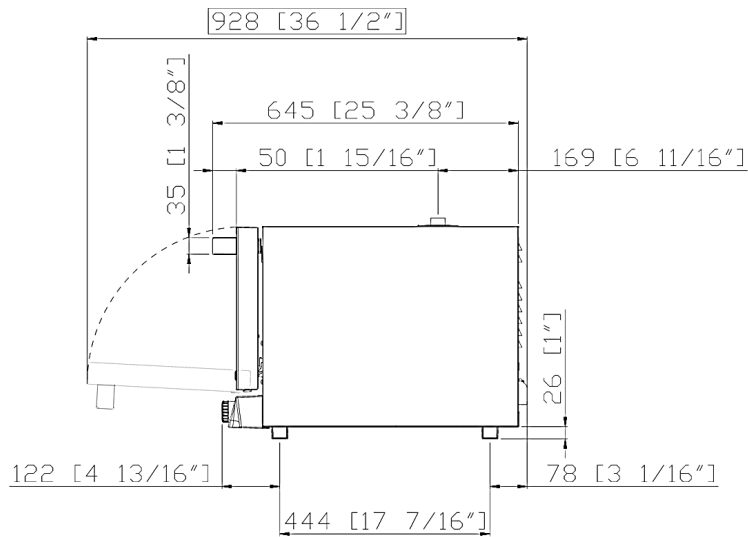

	English	Italiano	Español	Français	Deutsch
02	Electrical connection	Allacciamento elettrico	Conexión eléctrica	Raccordement électrique	Elektrischer Anschluss
08	Water connection	Allacciamento idrico	Conexión de agua	Raccordement à l'eau	Wasseranschluss
09	Gas connection	Allacciamento gas	Conexión de gas	Raccordement au gaz	Gasanschluss
11	Water drain	Scarico acqua	Desagüe del agua	Evacuation	Abflussrohr
12	Smoke exhaust	Scarico fumi	Salida de humos	Aspiration des fumées	Abluftrohr
13	Accessories connection	Collegamento accessori	Conexión de accesorios	Connexion des accessoires	Anschluss des Zubehörs
27	Cooling air outlet	Uscita aria di raffreddamento	Salida aire de enfriamiento	Sortie air de refroidissement	Kühlluftaustritt
30	Combustion fumes	Fumi di combustione	Gases de combustión	Fumées de combustion	Abgasse
31	Air inlet	Ingresso aria	Entrada de aire	Entrée d'air	Lufteinlass
	Русский	中文	Português		
02	Электрическое подключение	电源连接	Conexão elétrica		
08	Подключение к воде	水连接	Conexão hídrica		
09	Подключение к газу	燃气连接	Conexão gás		
11	Выход воды	排水	Saída de água		
12	Выход газов	排烟	Saída de fumaça		
13	Подключение аксессуаров	配件连接	Conexão de acessórios		
27	Выход охлаждающего воздуха	冷却空气出口	Saída do ar de refrigeração		
30	Продукты горения	燃烧烟雾	Fumaça de combustão		
31	Воздухозаборник	空气入口	Entrada de ar		

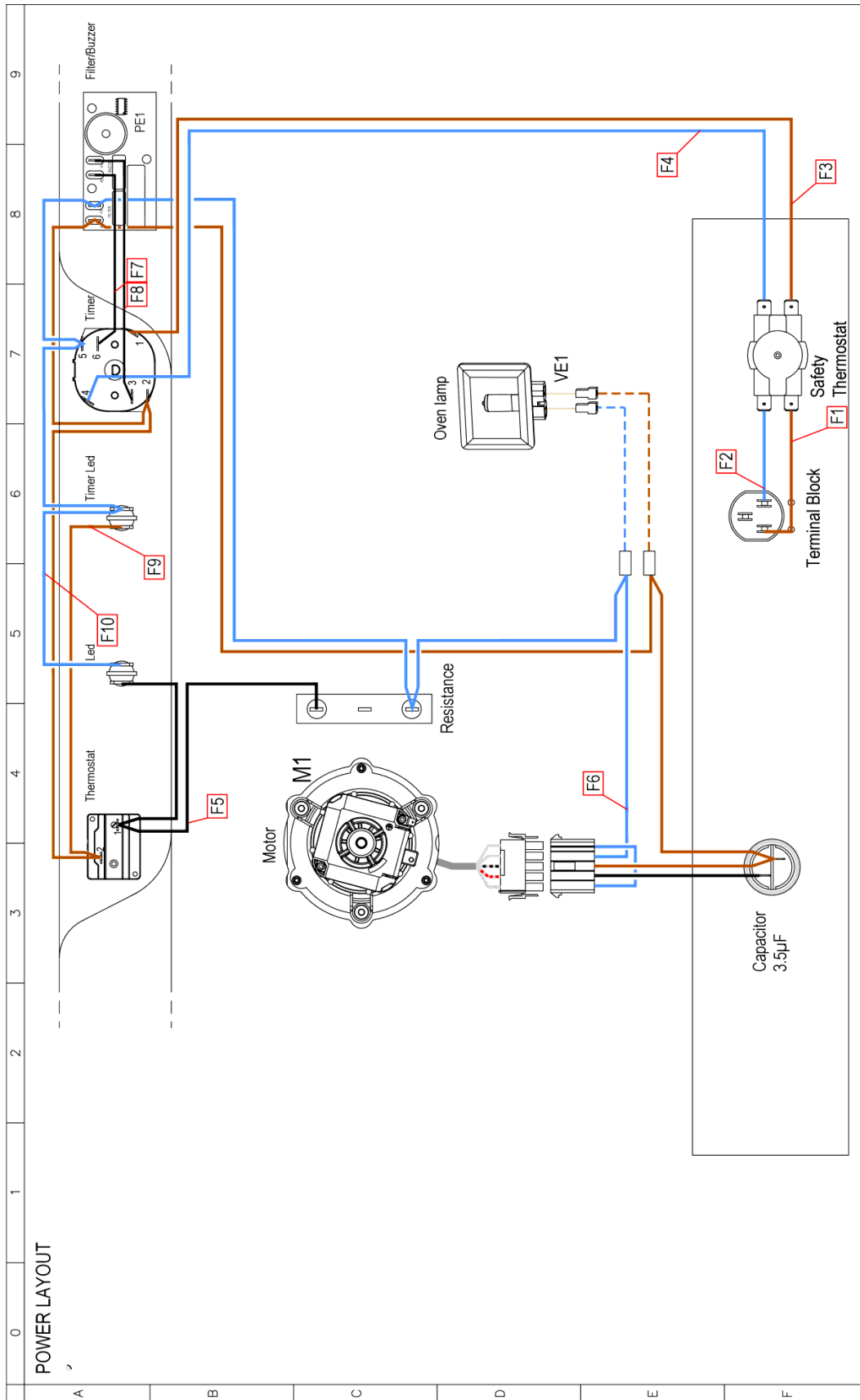

		0	1	2	3	4	5	6	7	8	9	
A	B	<b>PLUG MODEL CONFIGURATION</b>										
		Schuko Plug for European model : XENA-03HS-MADN										
		BS1363 Plug for British model : XUNA-03HS-MADN										
C	D	NEMA L6-20P Plug for LatAmerican model : XLNA-03HS-MADN										
		AU2-15P Plug for Australian model : XONA-03HS-MADN										
E	F	NBR14136 Plug for Brazilian model : XBNA-03HS-MADN										